

# Grupo Mantis

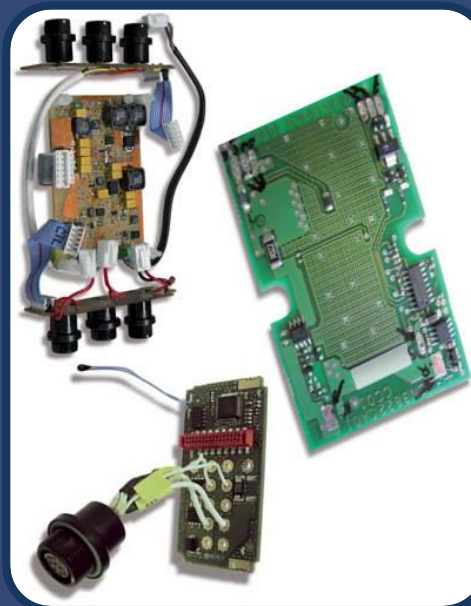

2020

## COMFUT - Fuente Alimentación



---

# Art. 83 - Rolhus: Robot limpieza automática de huertas solares

---



---

# Art. 83 - Rolhus: Robot limpieza automática de huertas solares

---



Art. 83 - Robot manipulador de teclados de helicópteros

**AIRBUS** (Eurocopter)



Art. 83 - Robot manipulador de teclados de helicópteros

**AIRBUS** (Eurocopter)

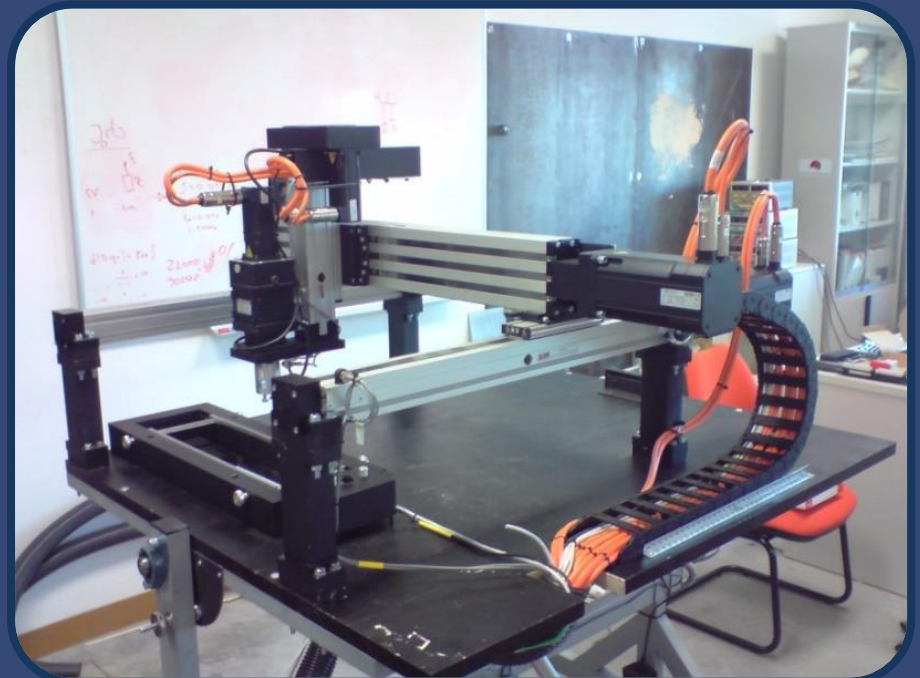
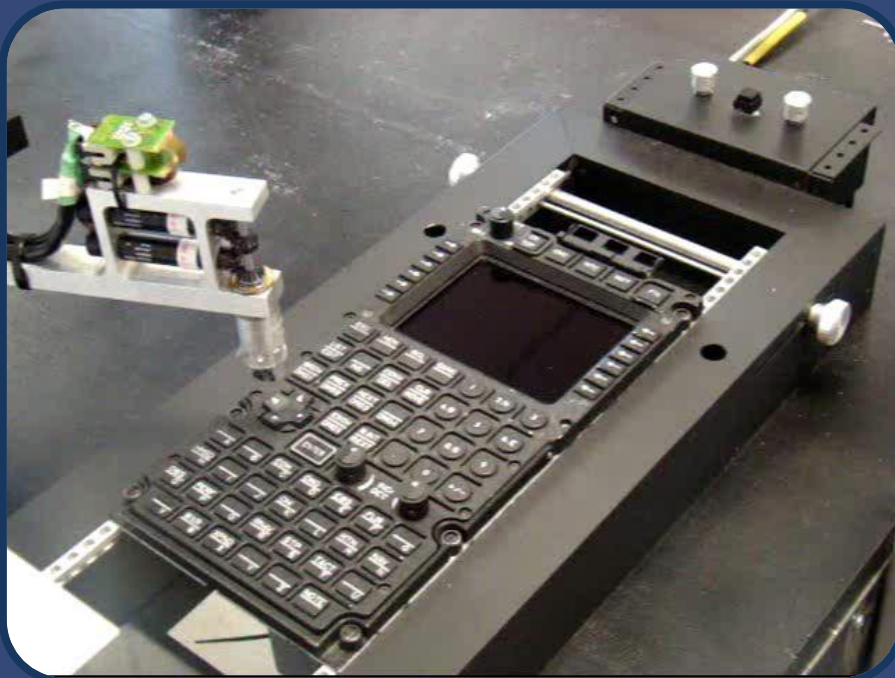

# Silla robótica con capacidad para subir escaleras



Silla de ruedas con capacidad para subir escaleras



---

# Art. 83 - Robot Cuadrúpedo: LEBREL y DOGO

---

## indra

---

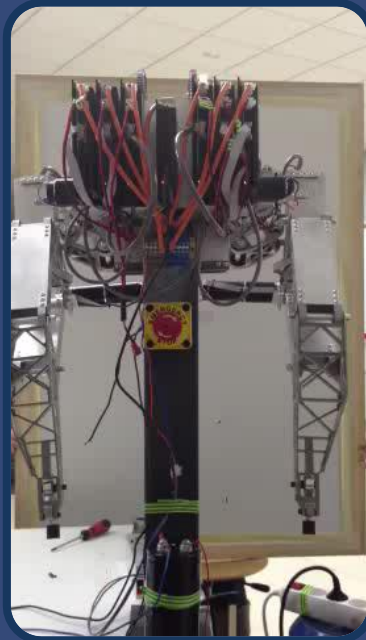



---

Art. 83 - Robot Cuadrúpedo: LEBREL y DOGO

---

**indra**

---



---

Art. 83 - Robot Cuadrúpedo: LEBREL y DOGO

---

**indra**

---

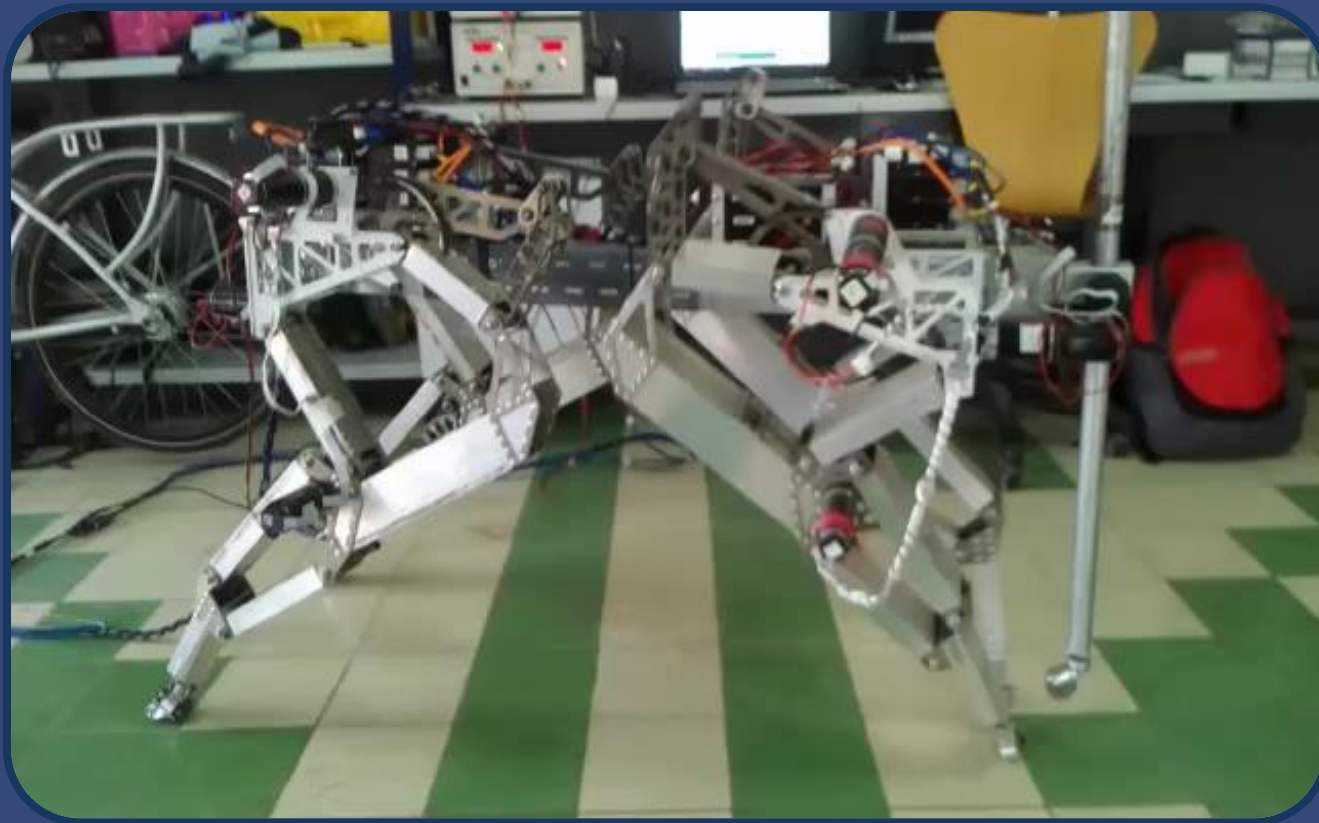

---

# Art. 83 - Robot Cuadrúpedo: LEBREL y DOGO

---

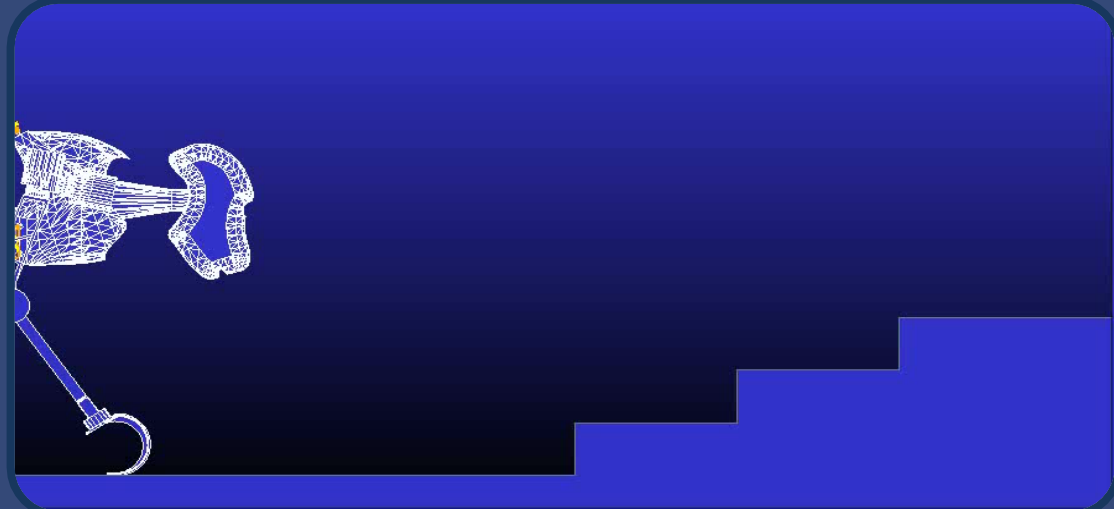

---

# Art. 83 - Robot para la monda automática de flores de azafrán

---

tecno<sup>v</sup>á

---

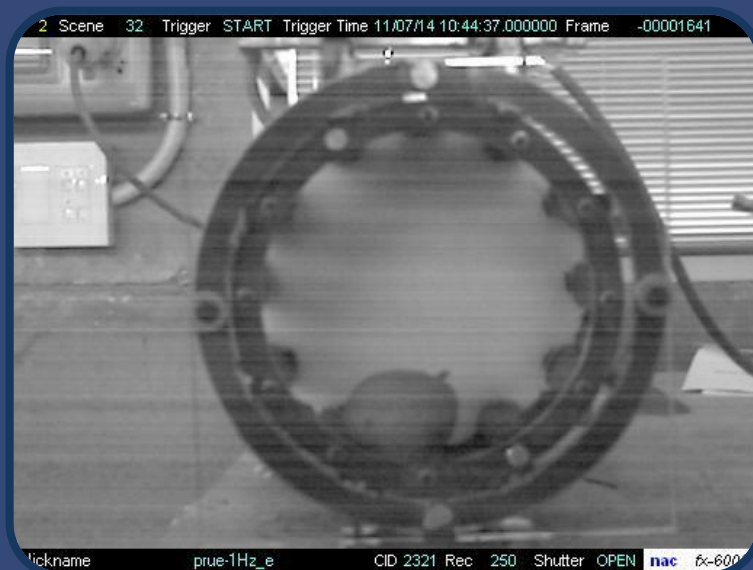

---

# Art. 83 - Robot para la monda automática de flores de azafrán

---



---

# Proyecto RETO Colaboración – Bike & Go

---

*ingenia*  
soluciones

---



# Proyecto RETO Colaboración – Ebrain

*clysema*  
climatización

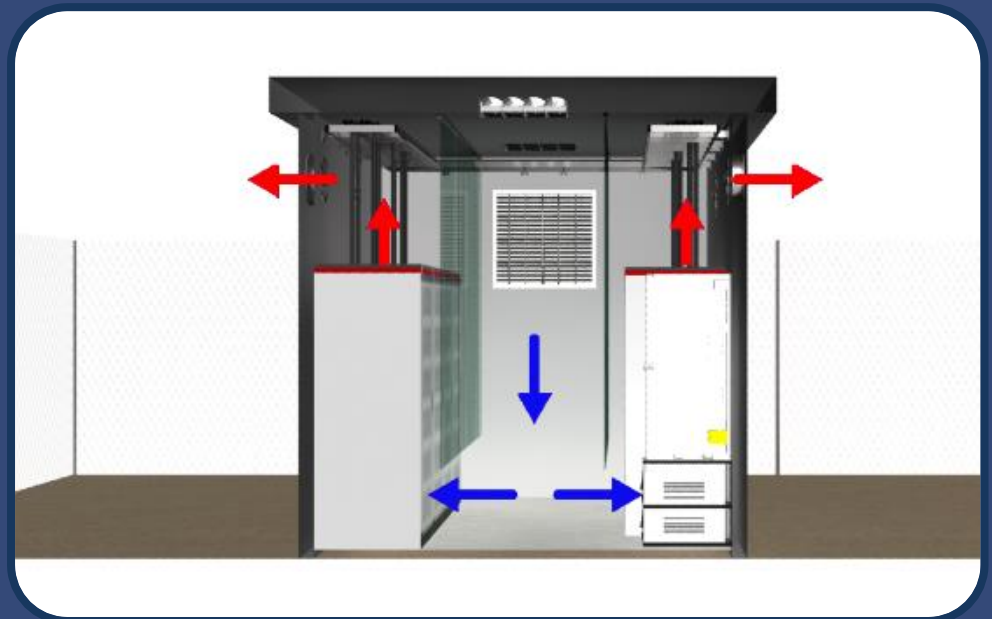
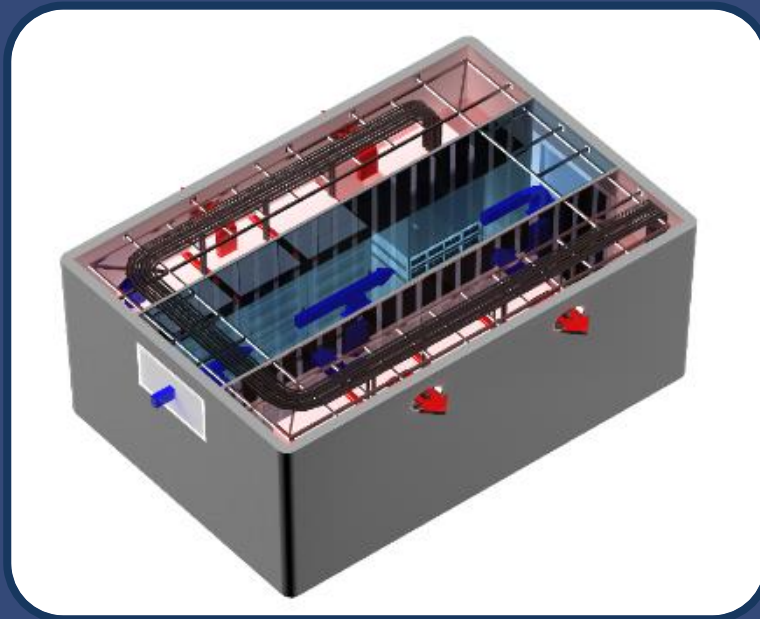

---

# Art. 83 – Seguidor solar

---

## indra

---

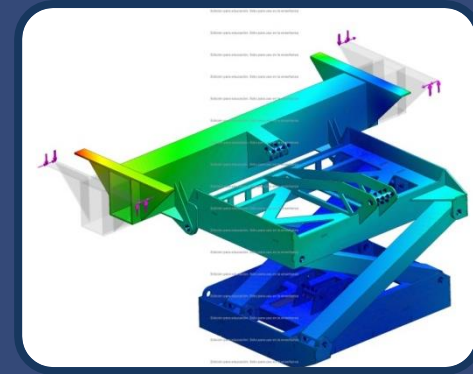
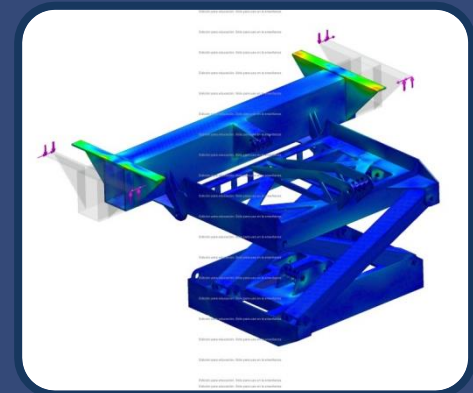



---

# Art. 83 – Modificación estructural de seguidor solar

---

## X-ELI<sup>+</sup>

---



## Art. 83 – Modificación estructural de seguidor solar

# X-ELI⊕

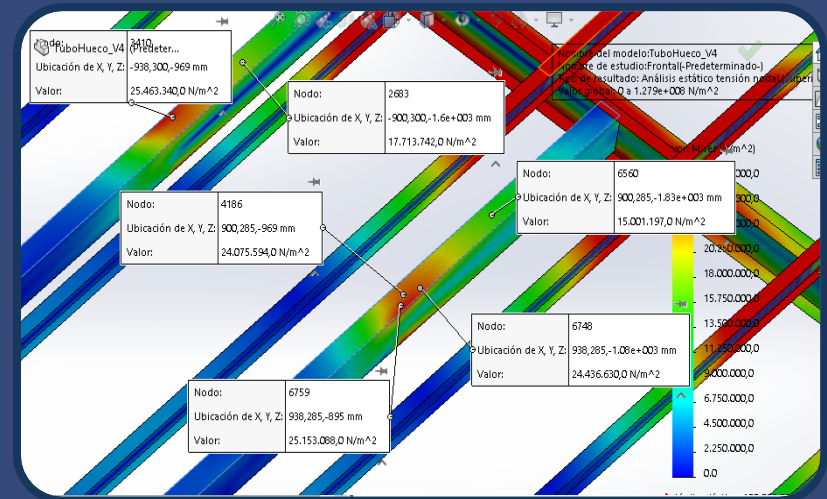

---

# Art. 83 – Banco de Ensayo de Frenos

---

## indra

---

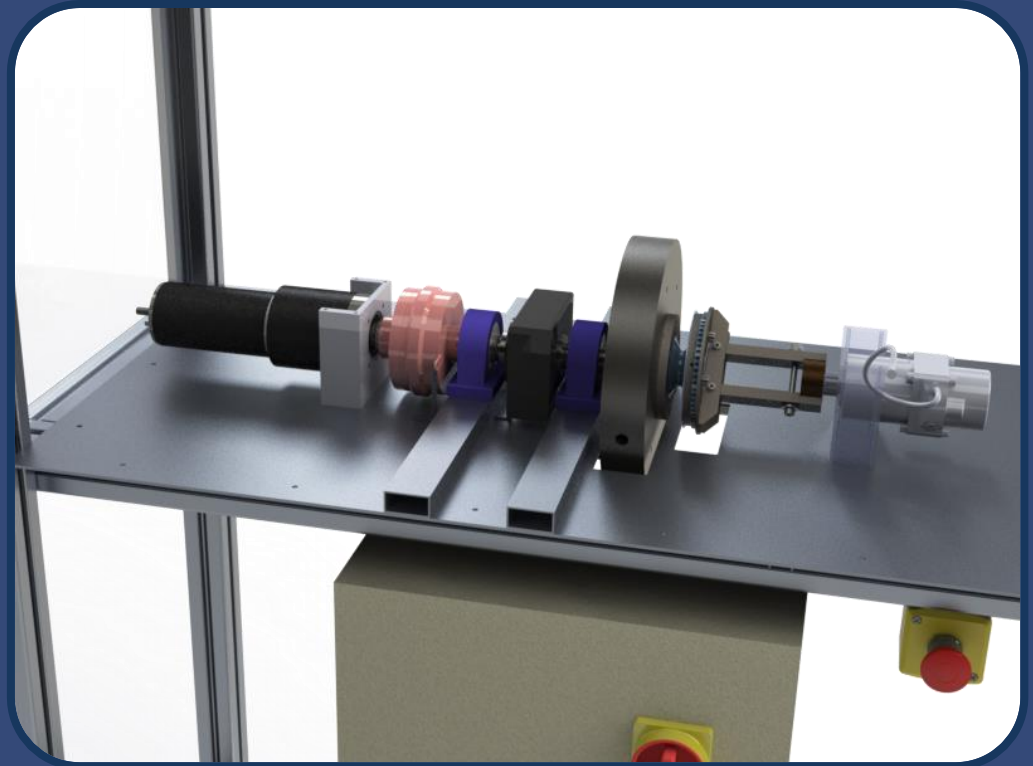

---

# Art. 83 – Banco de Ensayo de Frenos

---

## indra

---

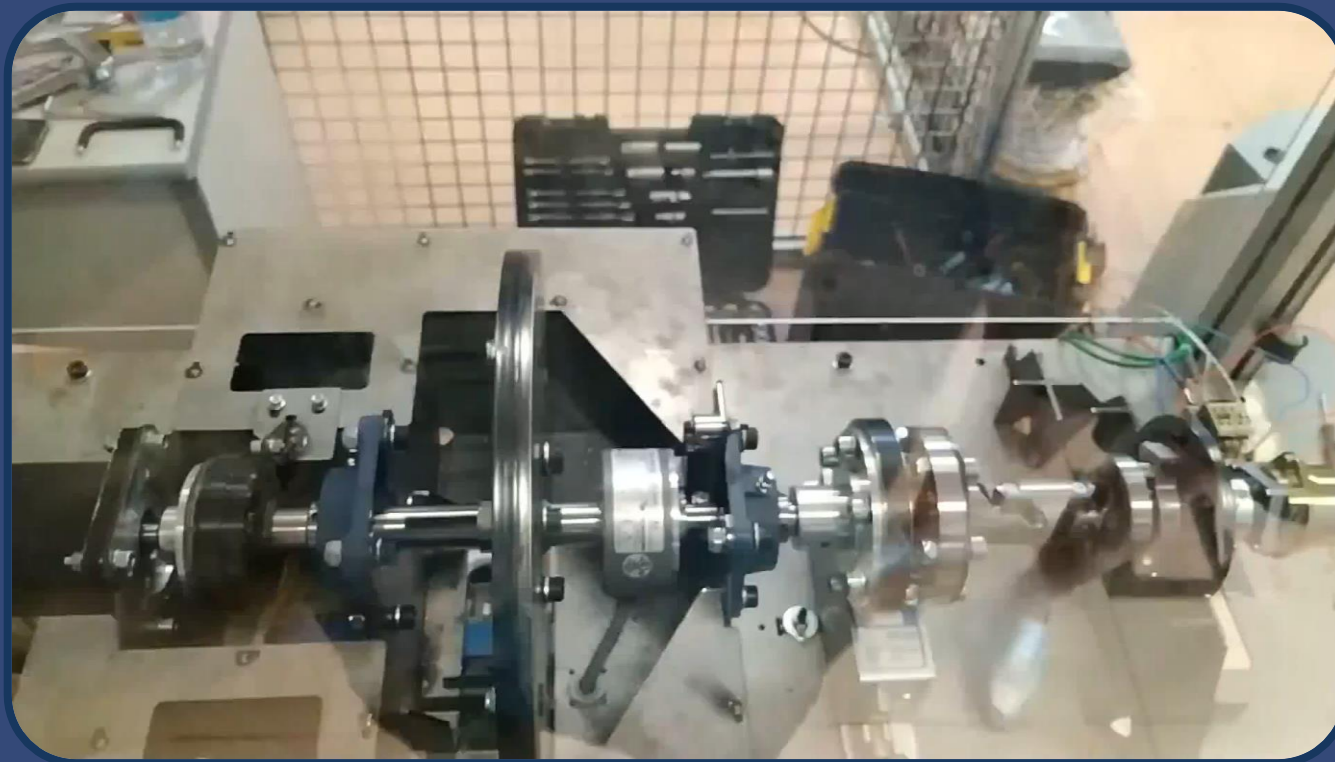

# Evaluación de superficies deportivas

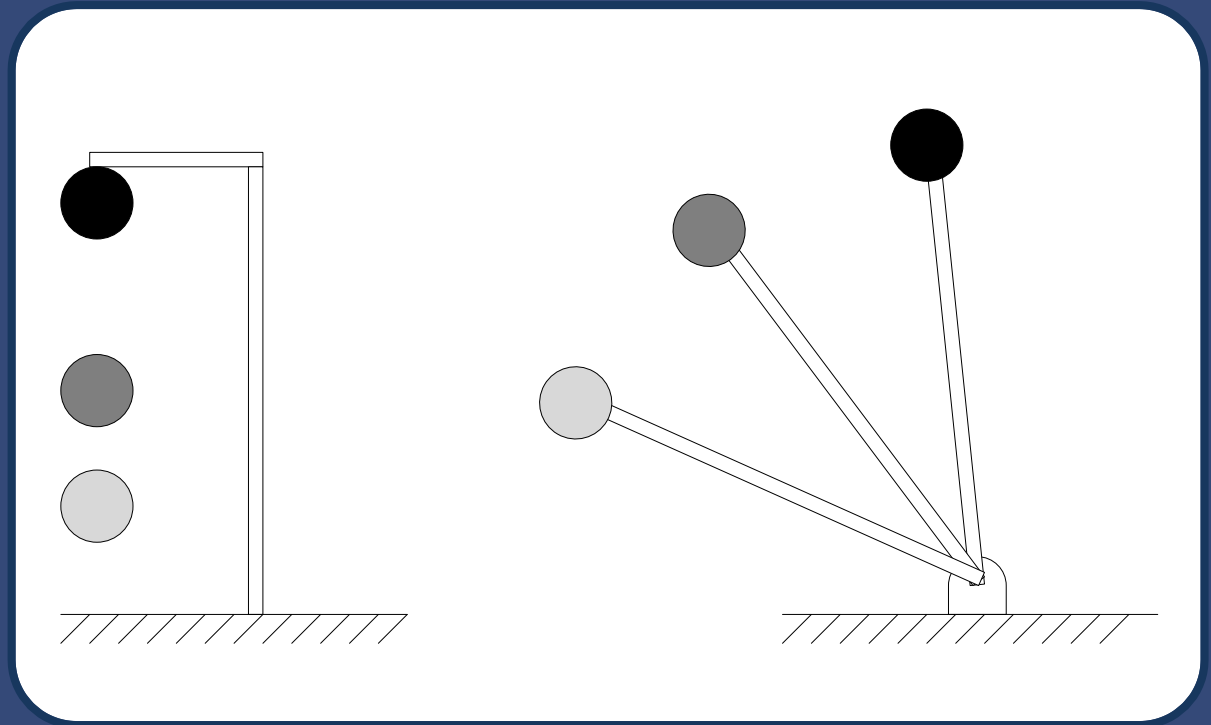

# Evaluación de superficies deportivas

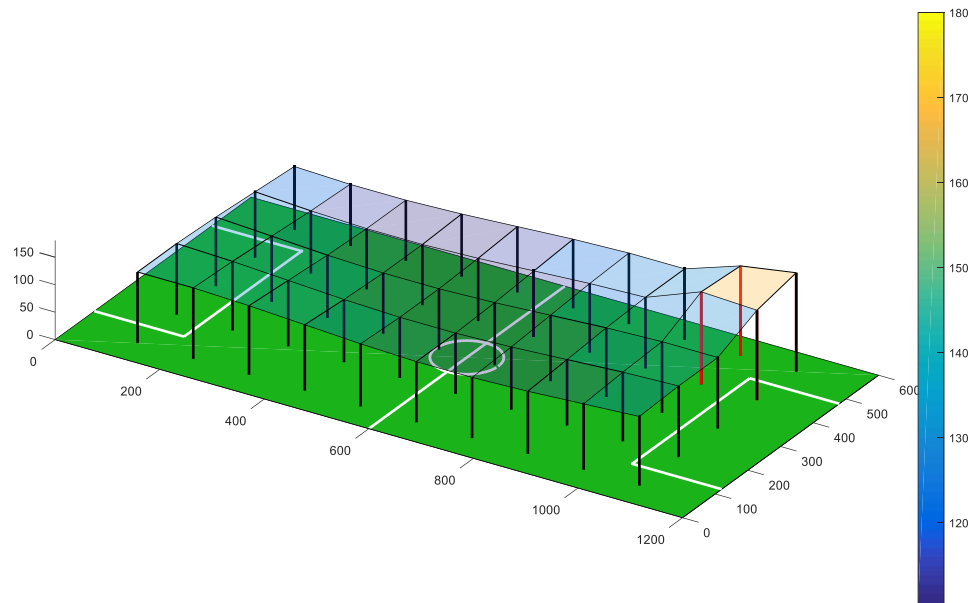

# Robótica mediante cables

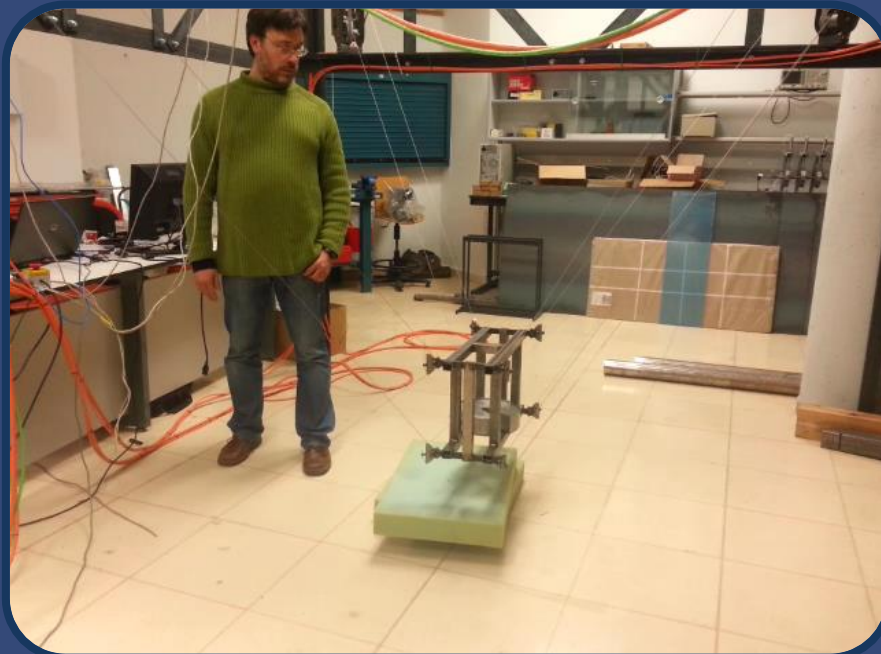

# Robótica mediante cables

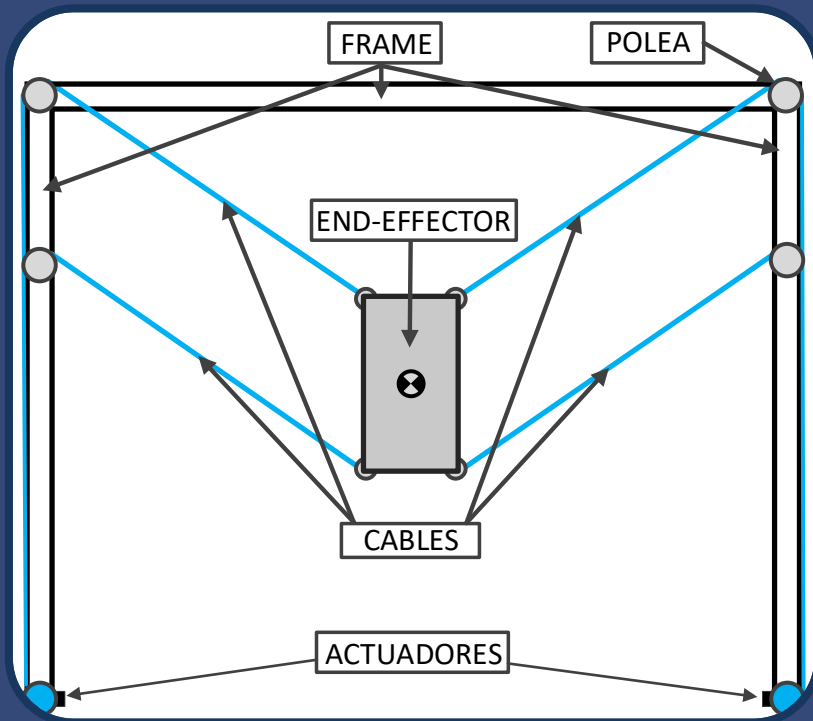



# Robótica mediante cables

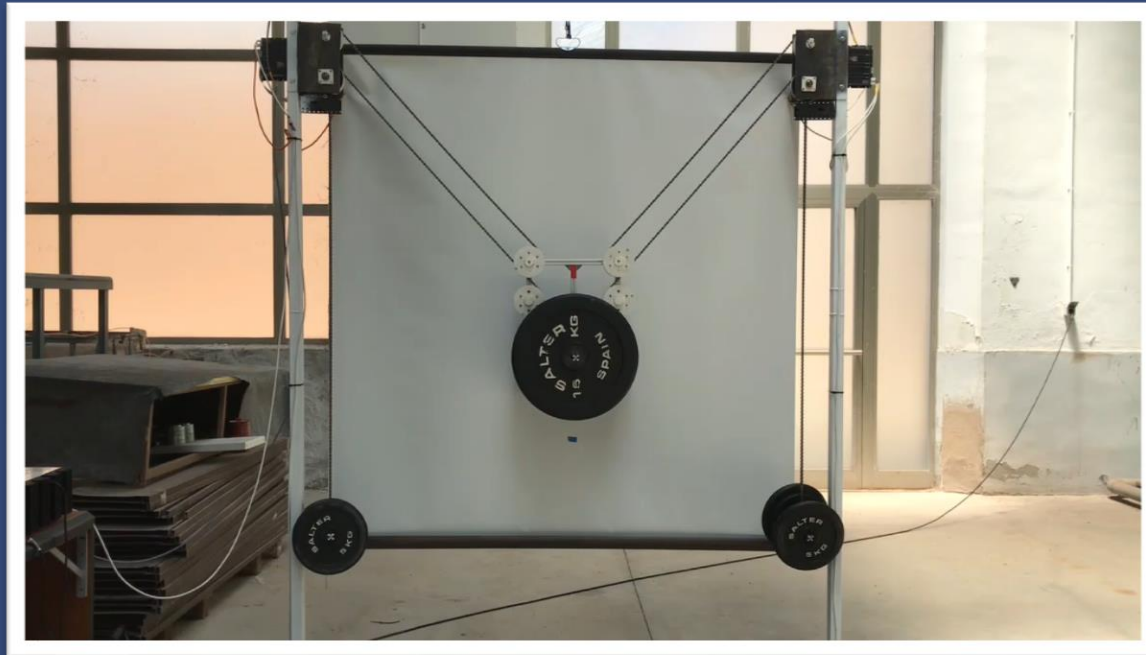

# Robótica mediante cables

**Usuario:** Emilio Barrios Torres  
**Farmacéutico:** 13-6-2019 16:19:36

**Documentos lectura/escritura:**  
 Tabla Lectura: MatrizDatos\_15.xlsx  
 Archivo Escritura: ListaMovimientos\_2.txt

**Selección de medicamentos:**  
 Medicamentos:  Hiperhise,  Hiperhise,  Hiperhise,  Hiperhise

**Datos:**  
 Precio (€): 1  
 Cantidad (uds.): 98  
 Posición X (m): 6  
 Posición Y (m): 1.2

**Medicamento** | **Botón**  
 Paracetamol |   
 Agua Oxigenada |   
 Alcohol |   
 Ibuprofeno |   
 Naloxona |

**Alarmas:**  
 - REALIZANDO HOME (13/6/2019 a las 16:18:20)  
 - INICIANDO SESIÓN COMO Farmacéutico: Emilio Barrios Torres. (13/6/2019 a las 16:18:45)  
 - HOME TERMINADO. (13/6/2019 a las 16:18:48)

**Trayectoria:**  
 Frame  
 Workspace  
 Axes

**Trayectoria Ordenada:**

| Orden | Medicamento | Pos. X (m) | Pos. Y (m) | Stock (uds.) | Precio (€) |
|-------|-------------|------------|------------|--------------|------------|
|       |             |            |            |              |            |

**Ajuste de Imagen:** Nombre: Figura1

**SEÑOR GORDO COMPANY**

# Robótica mediante cables

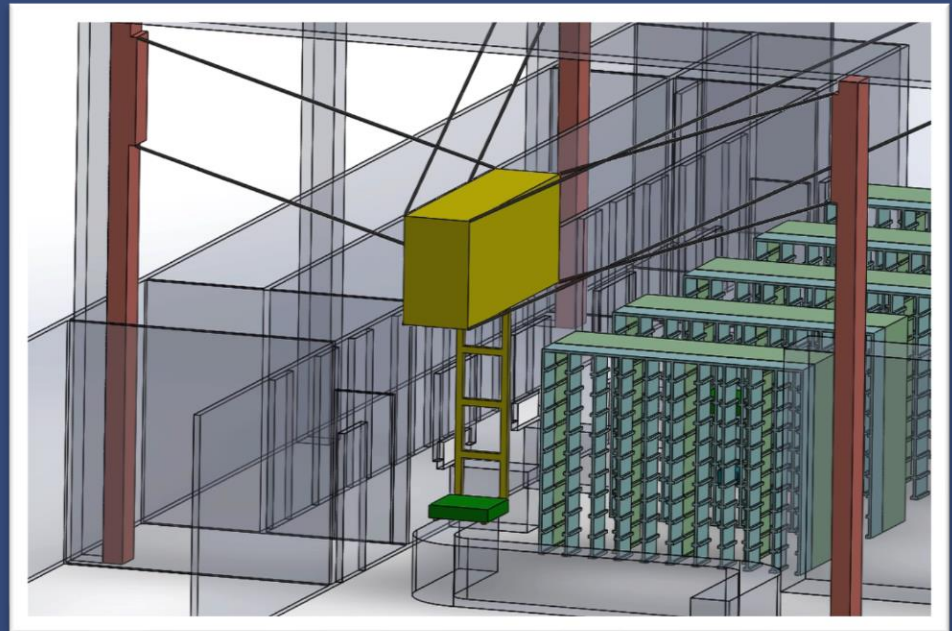
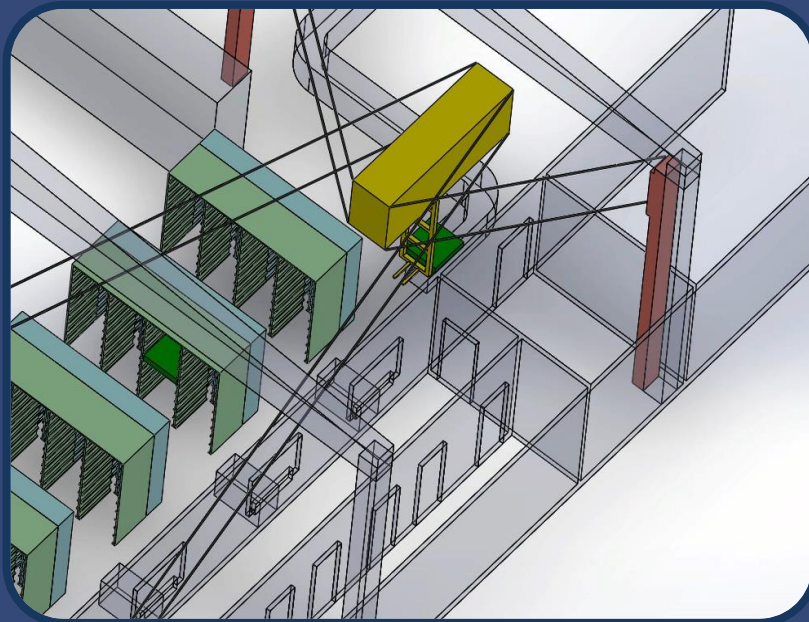

# Proyecto H2020 – DESDEMONA

Consorcio Europeo (8 PARTNERS)

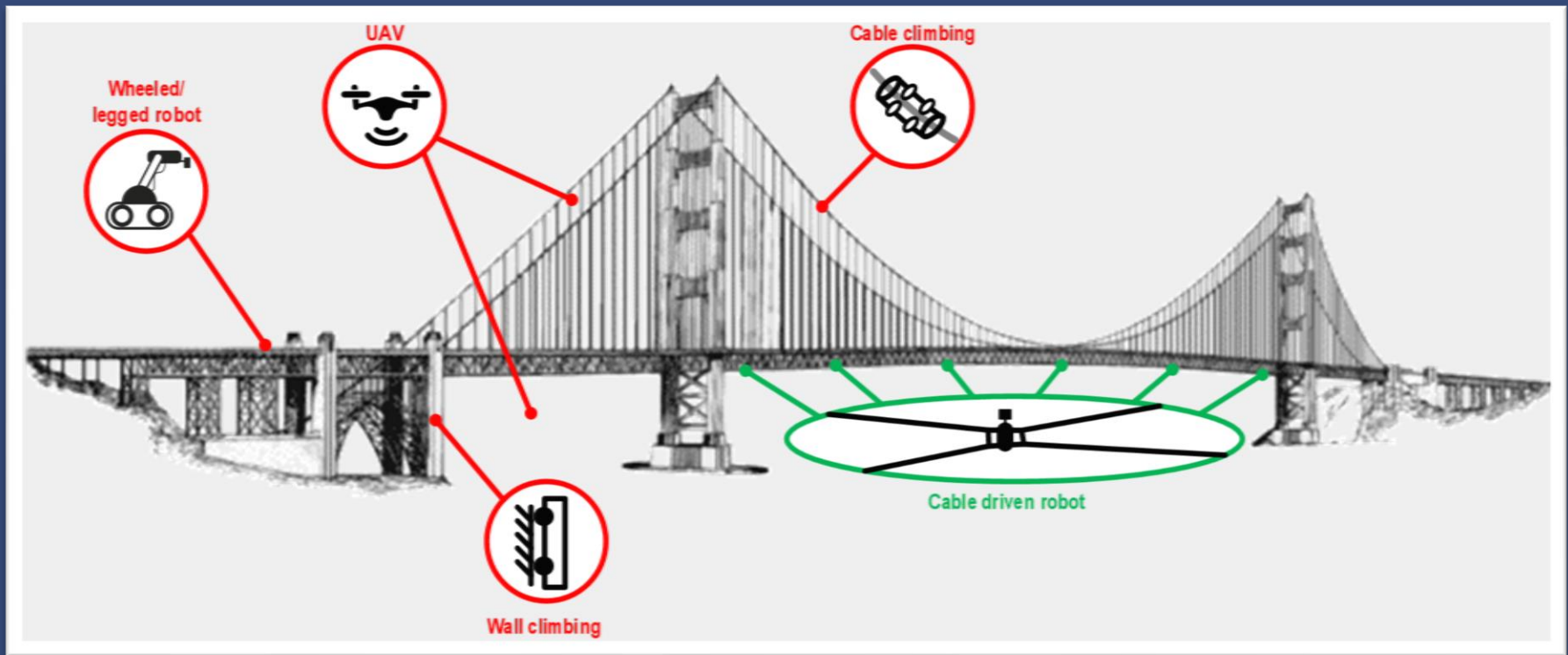

---

# Proyecto H2020 – DESDEMONA

---

Consorcio Europeo (8 PARTNERS)

---



## Proyecto H2020 – DESDEMONA

Consorcio Europeo (8 PARTNERS)

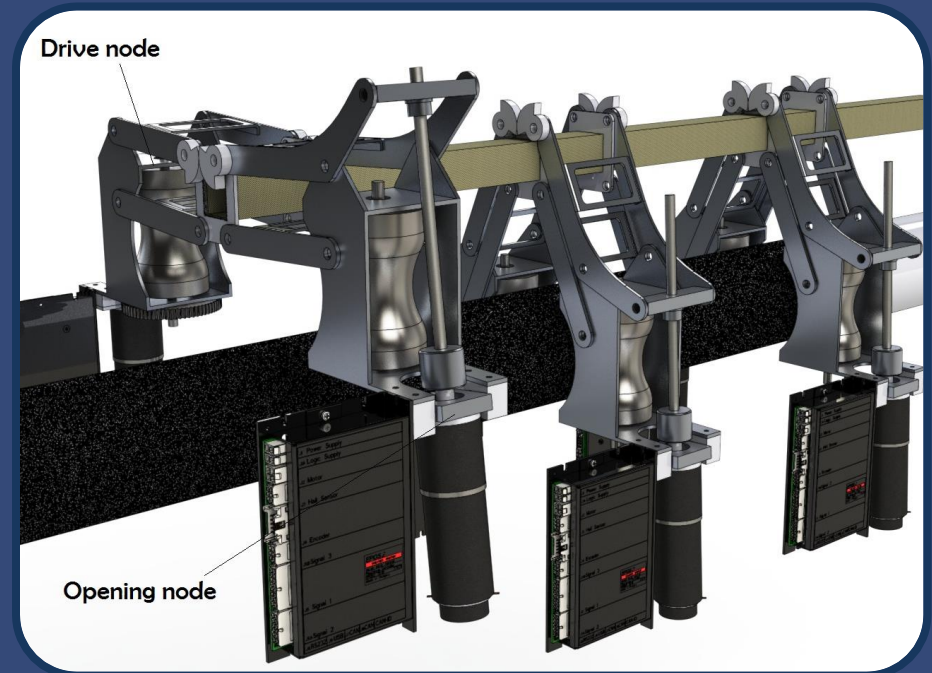
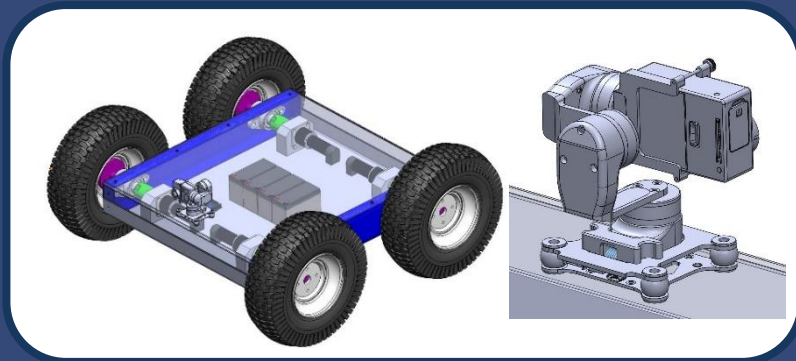

## Proyecto H2020 – DESDEMONA

Consorcio Europeo (8 PARTNERS)

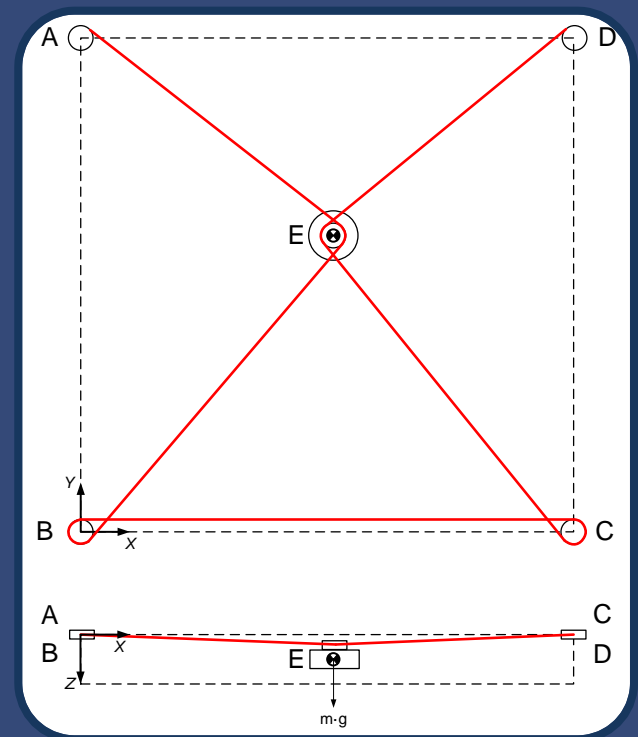
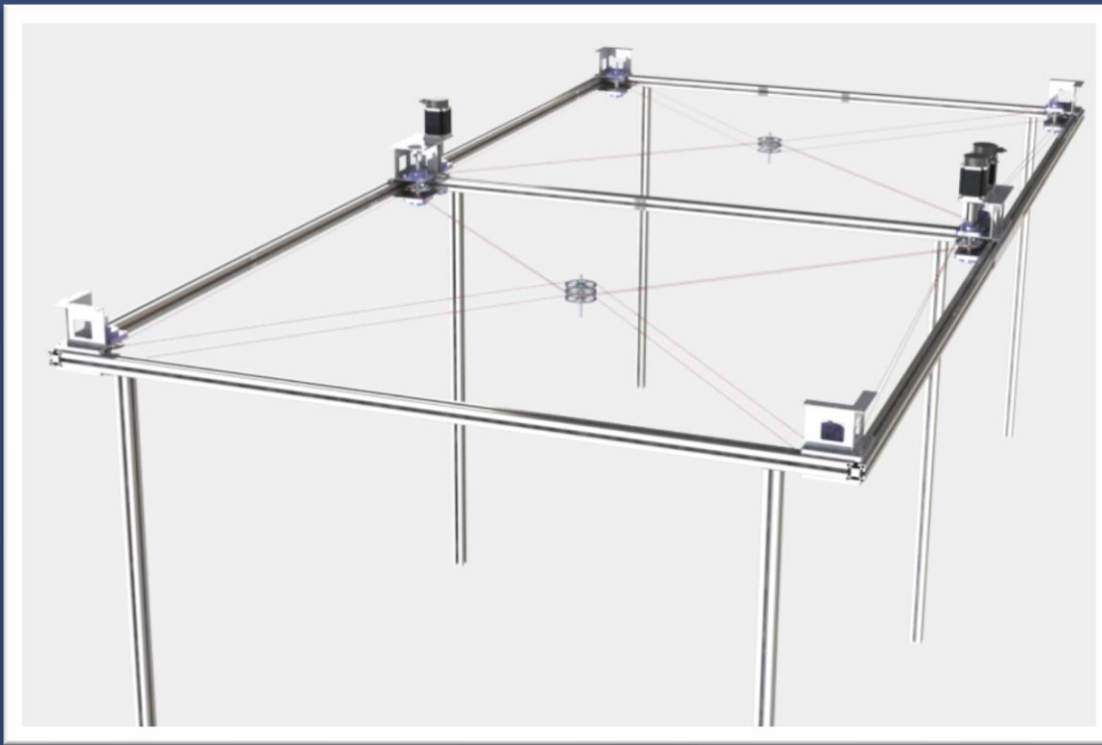

---

# Proyecto H2020 – DESDEMONA

---

Consorcio Europeo (8 PARTNERS)

---

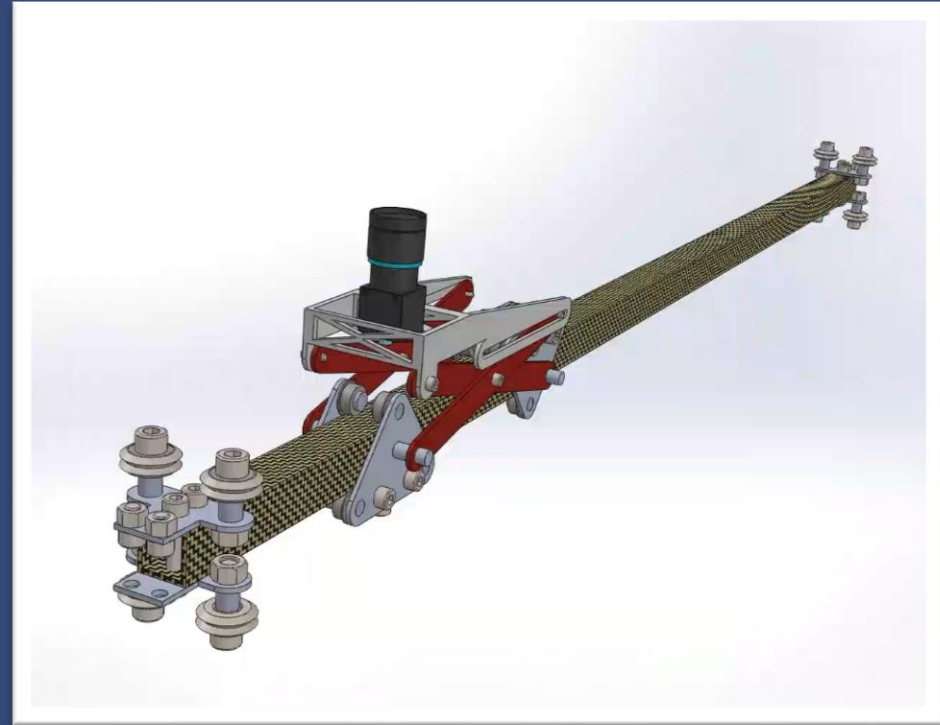
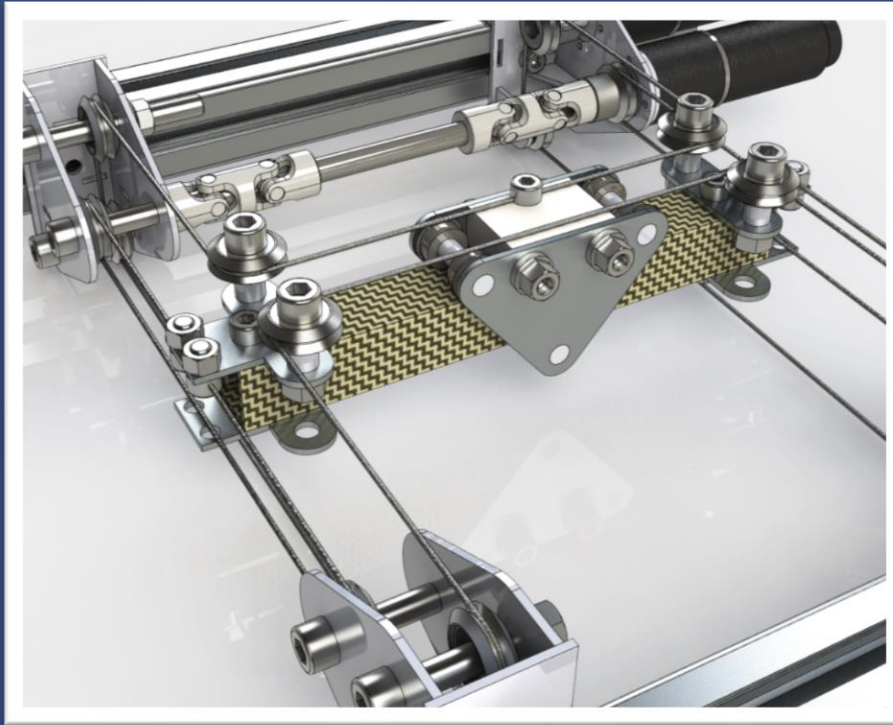



---

# Proyecto H2020 – DESDEMONA

---

Consorcio Europeo (8 PARTNERS)

---



## Actividad:

- Robótica Aplicada
- Visión por Computador
- Diseño Mecánico
- Control de Procesos
- Comunicaciones Industriales
- Sistemas de Aprendizaje
- Realización de Aplicaciones
- Formación Personalizada
- Asesoramiento Técnico
- Asesoramiento Desgravación Fiscal

**Grupo MANTIS**

**Gracias por vuestra atención**

2020